

Internal Manhole Housing Grab

The ideal grab for the transport of manhole grates according to DIN EN 124, DIN 1229

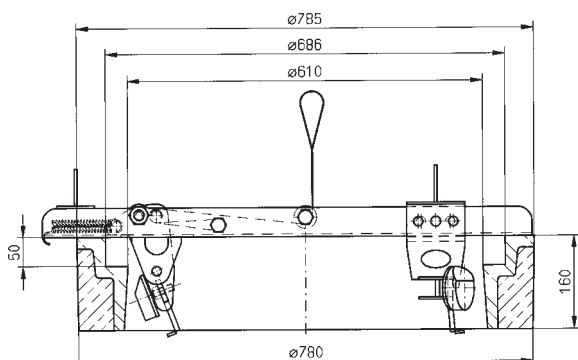

- For the **transport of housing and cover** with manhole cover vents* according to EN 124 /DIN 1229.
- **Great safety** due to huge lever force.
- **Sling** instead of chain/rope: low weight, no twisting, no injuries.
- Simply pull stop bolt to pick up the load.
- **Automatic opening** due to spring tension.
- **Easy handling** by compact and convenient construction.
- **The equipment is galvanized.**



* The manhole cover vents are not standard. Therefore it cannot be guaranteed that both load hooks fit each individual cover.

Order No.	Model	Carrying Capacity kg	Clamping Range mm	Weight Approx. kg
136 100	RGI-610	200	610 / 625	12