

200

Rope Winches

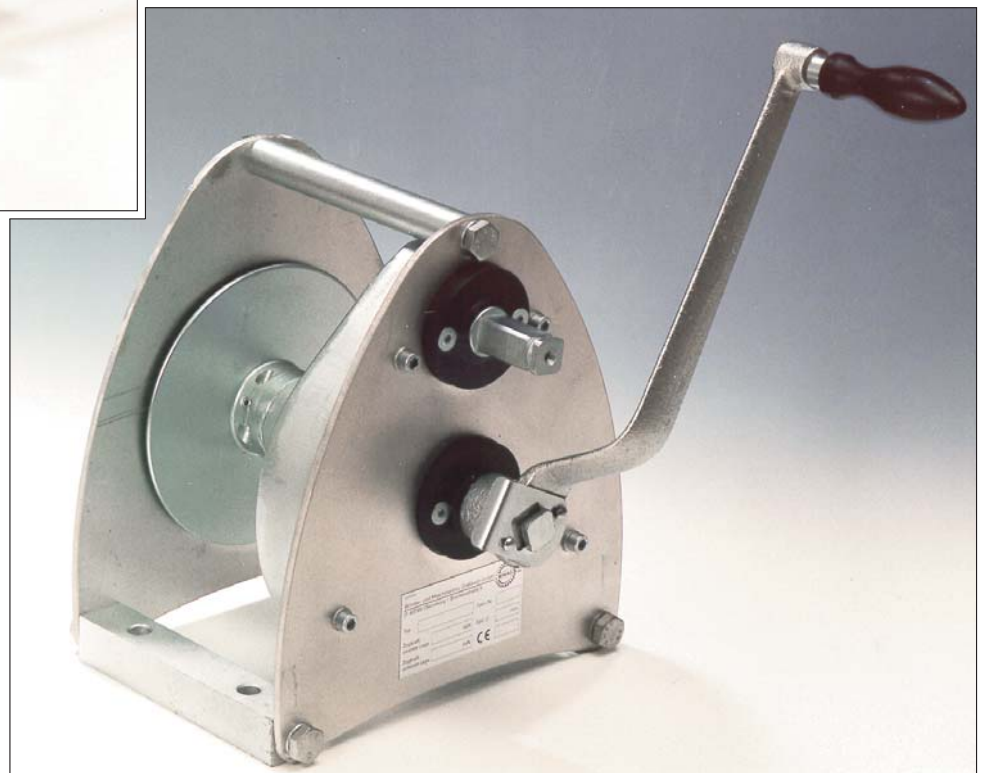

- Automatic load-pressure brake
- Solid and galvanized housing
- Closed gear

100 kg



Specification:

The Winch SW 100 is characterised by a simple design. It is corrosion-proof **galvanized**, easy to run and can be used for all purposes. **Solid construction** via closed housing.

The SW 100 is equipped with an automatic axial load-pressure brake with safety catch which holds the load securely and safely in any position.

The gear is completely encapsulated. The bearing is equipped with **plain bearings** requiring no maintenance.

The crank is equipped with a turnable handle. The crank arm is **continuously adjustable** in length and can be **removed** in an unloaded condition.

The winch can be simply fixed to a wall or to a console. The winch is constructed in accordance with the Regulations for the Prevention of Accidents, VBG 8.

Delivered unit:

Winch with crank. Supplied without fixing material or rope.

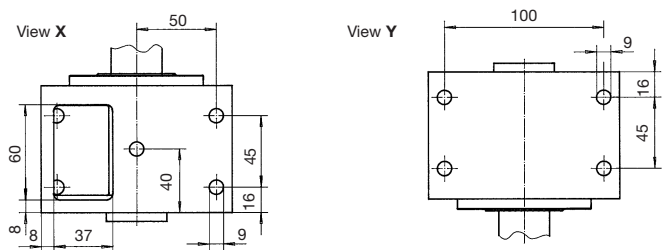
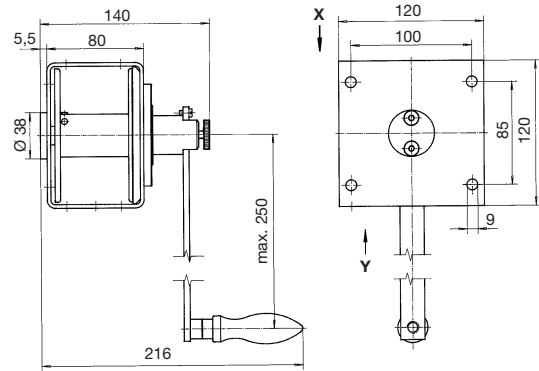

Order No.	Model	Pulling Force 1st Layer	Pulling Force 10th Layer	Minimum Load *	Manual Force	Rope Ø	Max Rope Capacity	Max Crank Radius	Average Stroke/Rotation	Weight
200 100	SW 100	100 kg	50 kg	15 kg	15 kg	3 mm	35 m	250 mm	200 mm	3 kg

* The winch must be operated with the indicated minimum load, otherwise the brake will not function.

Wire ropes on request.

650/3000 kg

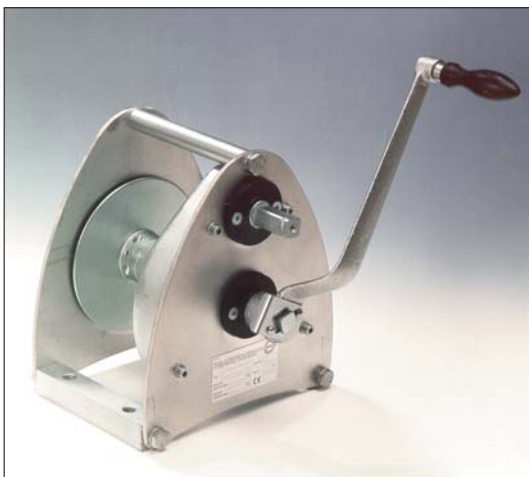

Specification:

The Winches SW 650, SW 1250 and SW 3000 are constructed with a **solid housing**. The equipment is completely galvanized. The winches are easy to run and can be used for all purposes. The winches are equipped with an automatic radial **load-pressure brake**, which holds the load securely and safely in any position.

The brake operates in **both directions**; therefore, the rope can be wound from both sides. **Noise is kept to a minimum** due to the drum brake; no safety catch.

The gear is **completely encapsulated**. It is equipped with **plain bearings requiring no maintenance**.

The crank is equipped with a **turnable handle** and can be **removed** or **exchanged** even in a **loaded condition**.

The winches are equipped with a **direct drum drive** for rapid winding/unwinding of the unloaded rope.

The winch can be simply fixed to a console or to the floor.

The unwinding of the rope is possible in four directions. The winches are constructed in accordance with the Regulations for the Prevention of Accidents, VBG 8.

Delivered unit:

Winch with crank. Supplied without fixing material or rope.

Order No.	Model	Pulling Force 1st Layer	Pulling Force Top Layer	Multiplication	Manual Force	Rope Ø	Max. Rope Capacity	Crank Radius	Average Stroke/Rotation	Weight
200 200	SW 650	650 kg	250 kg	7:1	12 kg	6 mm	34 m	250 mm	40 mm	10 kg
200 300	SW 1250	1250 kg	500 kg	13:1	15 kg	8 mm	80 m	400 mm	35 mm	30 kg
200 400	SW 3000	3000 kg	1500 kg	42:1	20 kg	12 mm	117 m	400 mm	20 mm	95 kg

Accessories and wire ropes on request.

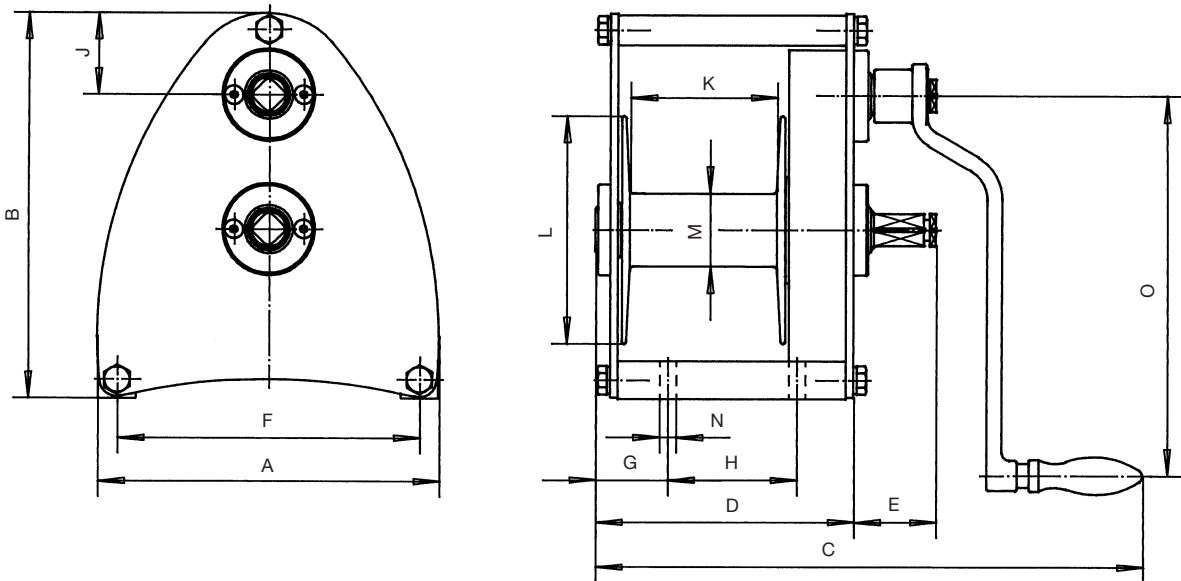

Dimension Model	A	B	C	D	E	F	G	H	J	K	L Ø	M Ø	N Ø	O
SW 650	226	254	362	170	55	200	48	85	54	97	150	48	11	250
SW 1250	370	402	492	263,5	55	330	53,5	170	79,5	166	238	76	13	400
SW 3000	526	575	593	363,5	56,5	470	63,5	250	155	220	345	127	18,5	400

206

Motorised Crank

- Worm drive to be fixed to WIMAG rope winches
- Safety clutch operated by torque
- Construction in accordance with the Regulations for the Prevention of Accidents

Use motorised crank and not the manual crank and place it on the square spigot of the rope winch. It guarantees easy operation without force for large lifting heights.

The crank motor is equipped with a deadmans control as standard, guaranteeing maximum safety during lifting operation.

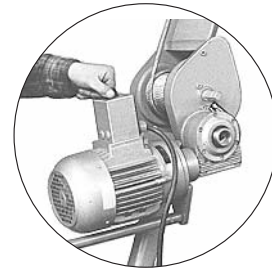

Order No.		206 100	206 200
Model		KM 1,1 D	KM 1,1 W
Type of Motor		Rotary Current	Alternating Current
Voltage	Volt	380	220
Frequency	Hz	50	50
Motor Power	kW	1,1	1,1
	Amp	2,6	5,1
Operating Time	% ED	40	100
Motor Speed	approx. min ⁻¹	1400	1400
Gear Torque	Nm	125	125
Speed	min ⁻¹	71	71
Protective System	IP	54	54
Weight	approx. kg	30	33

Delivery unit per motor:
5 m cable with CEE plug and torque stop.

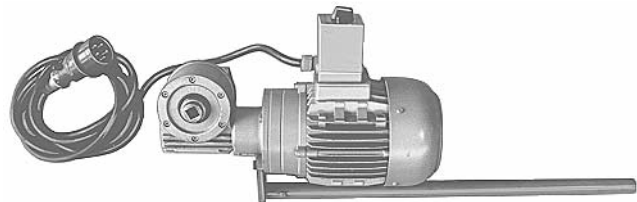

208

DIN Standard Steel Lifting Jack

Order No.	Order No.	Model	Carrying Capacity	Construction Height	Lifting Height	Height of Claw in its Lowest Position	Weight approx.
SIKU	RAKU		kg	mm	mm	mm	kg
208 010	208 011	ZW/DIN 1,5	1,500	725	350	70	12
208 020	208 021	ZW/DIN 3	3,000	725	350	75	20
208 030	208 031	ZW/DIN 5	5,000	725	300	70	24
208 040	208 041	ZW/DIN 10	10,000	800	300	90	42
208 050	208 051	ZW 15*	15,000	800	340	95	58

Steel lifting jacks in accordance with DIN 7355, with lifting jacket. SIKU = safety crank and folding handle, RAKU = ratchet safety crank. * DIN Draft

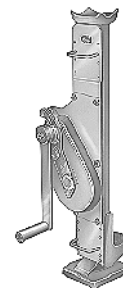

209

Sluice Lifting Jack

Order No.	Order No.	Model	Tractive Power	Rack Length	Lifting Height	Measurements of Bore Holes		Weight approx.
						Tread mm	Back Plate mm	
SIKU	RAKU		kg	mm	mm			kg
209 010	209 011	S 1,5	1,500	1150	800	130 x 70	130 x 160	14
209 020	209 021	S 3	3,000	1260	800	130 x 80	165 x 220	24
209 030	209 031	S 5	5,000	1280	800	200 x 100	180 x 250	32
209 040	209 041	S 10	10,000	1405	800	280 x 120	220 x 310	53
209 050	209 051	S 15	15,000	1450	800	280 x 145	375 x 235	65

Sluice lifting jacks are available with tread or back plate (flat iron frame). Other sizes of lifting heights and rack lengths on request.



with back plate



with tread