

# 505

## Gantry Cranes

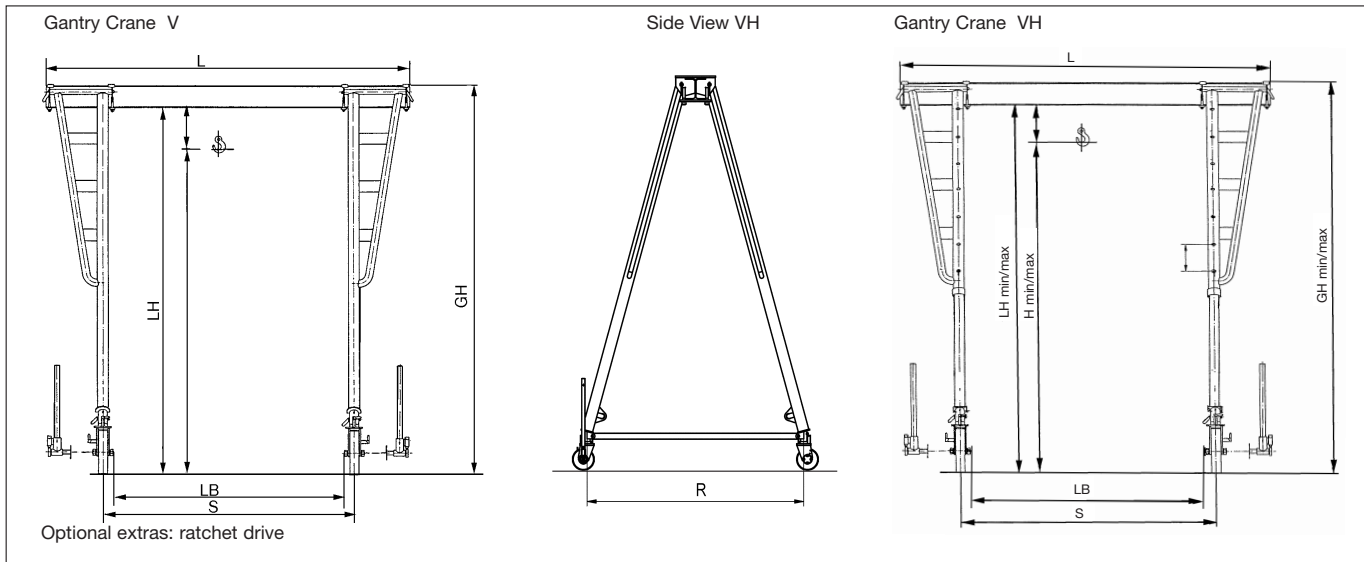

- Fast erection and dismantling via all bolt connection
- Construction according to UVV and VDE Regulations, classification according to DIN 15 018, H2/B2
- Light weight due to light tubular construction
- Welding Verification, in-house crane experts with many years of experience in crane construction



The Gantry Crane V is designed for indoor and outside use and can be equipped with any manual or electric hoist. The strong V-supports allow a high carrying capacity, a high span and a high construction height. The clamping connection between V-supports and beam enables a continuously adjustable span. The all bolt connection guarantees an easy and fast erection of the crane. Big steel wheels of a diameter of approx. 400 mm allow an easy run. For a simple moving of the crane on even and solid ground, the crane can be equipped with ratchet drive acting on 2 wheels. The wheels can be fixed at 90° intervals, two of them can be additionally locked. Coat of varnish: orange, RAL 2000.

The Gantry Crane **VH** can be adjusted in height via bolts.

Full assembly: crane with crane test book including a certified preliminary- and construction test, operating instructions, but without hoist.

All weight and measurement data are deemed to be approximate.

Order No.	Model	Carrying Capacity kg	Beam Length L mm	Beam Section PE	Span S mm	Clearance Height mm	Total Height mm	Wheel Base R mm	Weight kg	Order No.	Model	Max. Total Height mm	Min. Total Height mm
505 005	V-103	1.000	3000	200	2090	3785	4000	2100	500	505 205	VH-103	4000	2718
505 010	V-104	1.000	4000	200	3090	3785	4000	2100	530	505 210	VH-104	4000	2718
505 015	V-105	1.000	5000	200	4090	3785	4000	2100	580	505 215	VH-105	4000	2718
505 020	V-106	1.000	6000	220	5090	3765	4000	2100	650	505 220	VH-106	4000	2718
505 025	V-204	2.000	4000	240	3090	4740	5000	2600	630	505 225	VH-204	5000	3228
505 030	V-205	2.000	5000	270	4090	4710	5000	2600	700	505 230	VH-205	5000	3228
505 035	V-206	2.000	6000	270	5090	4710	5000	2600	780	505 235	VH-206	5000	3228
505 040	V-207	2.000	7000	300	6090	4680	5000	2600	900	505 240	VH-207	5000	3228
505 045	V-304	3.200	4000	300	3100	4680	5000	2600	750	505 245	VH-304	5000	3233
505 050	V-305	3.200	5000	300	4100	4680	5000	2600	850	505 250	VH-305	5000	3233
505 055	V-306	3.200	6000	330	5080	4650	5000	2600	950	505 255	VH-306	5000	3233
505 060	V-307	3.200	7000	360	6080	4620	5000	2600	1100	505 260	VH-307	5000	3233
505 065	V-505	5.000	5000	360	4100	4615	5000	2600	1000	505 265	VH-505	5000	3268
505 070	V-506	5.000	6000	400	5090	4575	5000	2600	1100	505 270	VH-506	5000	3268
505 075	V-507	5.000	7000	450	6090	4525	5000	2600	1180	505 275	VH-507	5000	3268
505 080	V-508	5.000	8000	450	7090	4525	5000	2600	1300	505 280	VH-508	5000	3268

Accessories: manual/electric hoist, trailing cable mains supply.

Special designs upon inquiry: modified carrying capacity, height, width, rubber tyres, track wheels, ratchet drive ...

Wheels available:

- 1 - steel as standard
- 2 - steel for tracks
- 3 - rubber tyres up to 3 t carrying capacity
- 4 - rubber tyres with ratchet drive

